



SPEAKER

TD508II_{WH}

TD510_{WH}

TD508II_{SU}

TD510_{SU}

TD508II_{BK}

TD510_{BK}

Owner's Manual

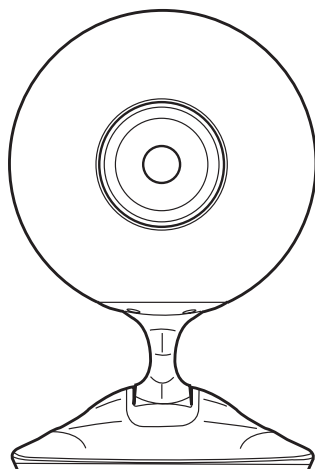
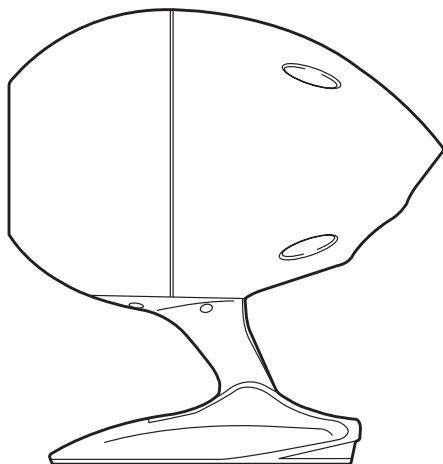

Thank you for purchasing the Eclipse TD Speaker.

Please read this Owner's Manual before use.

Be particularly sure to read the Important Safety Instructions section.

Keep this Owner's Manual together with the Warranty Certificate in a safe place for later reference.

FUJITSU TEN

Foreword

Contents

Using the Product Safely and Correctly	13
Precautions on Use	14
Name and Function of Each Part, and Connection	15
Adjusting the Angle of the Speaker	16
Fitting the Protective Mesh	18
Care / Specifications	19
Warranty and After Service	20

Accessories

speaker x 1

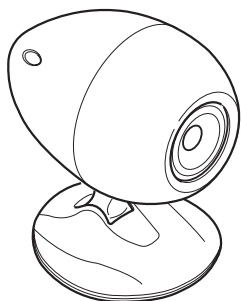

Hexagonal wrench x 1

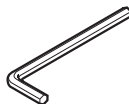

Eclipse TD logo sticker x 1



Protective cover x 1



Owner's Manual x 1

Warranty Certificate

* This product is a speaker which has been designed using Time Domain theory.

《What is Time Domain theory?》

Time domain recreates the changes that occur in sound waves over time from the moment of output until their disappearance. Its purpose is to reproduce those sound waves that are as close to the original recorded sound as possible. Time domain audio systems allow sound orientation and the nuances that are added by recorded performers to be faithfully reproduced.

Using the Product Safety Correctly

Before use

The warnings contained within this instruction manual and on the unit itself are to ensure safe and correct use of the unit and thus prevent injury to our customers or other people and damage to property. Please read and understand the warnings before continuing with the rest of this manual.



WARNING

These warnings represent occasions where improper use of the product may result in death or serious injury.



CAUTION

These cautions represent occasions where improper use of the product may result in serious injury or damage to the product.

WARNING

Do not place the unit in an elevated location. A fall may cause injury.

Do not open the cabinet of the unit. This may cause electric shock or injury. For internal inspection, repair or maintenance, please contact a Customer Service Center. Also, do not attempt to modify the unit. This may cause fire or electric shock.

Do not place the unit in the bathroom or anywhere exposed to rain. Do not use the unit in places with high humidity. This may cause fire or electric shock. Be particularly careful when using the unit in rainy weather or when it is snowing, at the beach or near water. Do not place above or near the unit, any flower vases, plant pots, cups, makeup, medicine or any vessel containing liquid or any small metal objects. In case any liquid or small metal objects enter the unit, fire or electric shock may result.

CAUTION

The unit should be placed on a hard, flat surface. Placing the unit on an unstable surface may cause it to fall over and cause injury.

Do not climb on or swing from the unit. In particular, care should be exercised when children are present. The unit may fall or break and cause injury.

Precautions on Use

Before turning the unit on or changing the input source, be sure to set the volume to Low. Sudden bursts of loud noise may cause damage to any connected speaker systems.

To avoid disturbance in your neighborhood, enjoy your unit at an appropriate volume. Remember that particularly at night, even low volumes carry well into surrounding areas. Help to maintain a pleasant living environment.

Always connect speaker with the power disconnected.

Be careful not to knock the unit over.

If the unit becomes dirty, use detergent on a soft cloth to wipe it down. Do not use thinners or gasoline.

Name and Function of Each Part, and Connection

The illustrations in this instruction manual show the TD510, but all the functions are shared with the TD508II.

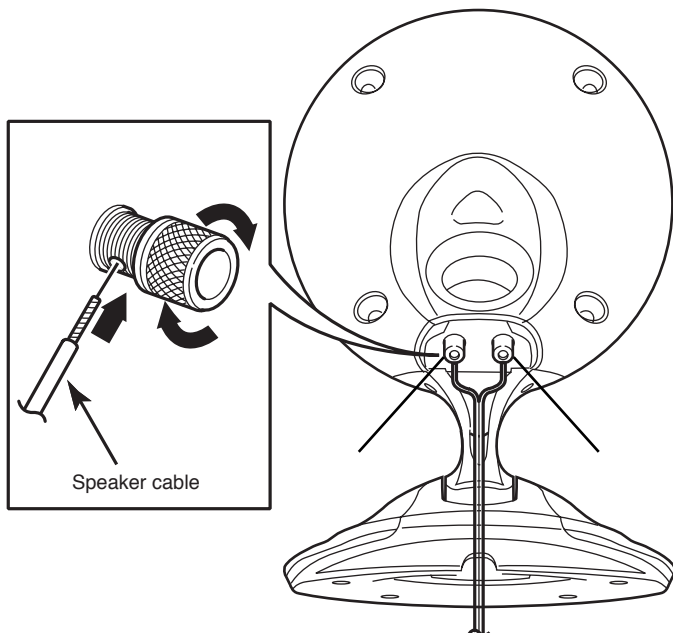

Speaker Input Terminals

Insert the ends of the speaker wires into the holes in the speaker input terminals and tighten the terminals.

When connecting the speakers, insert the ends of the speaker cables so that they do not touch neighbouring terminals or other parts.

Adjusting the Angle of the Speaker

[1] About speaker angle adjustment

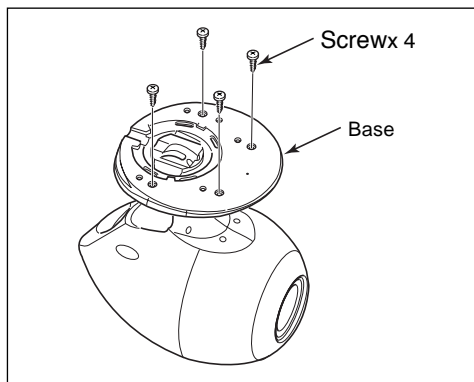

Remove the screws on the bottom face of the base.

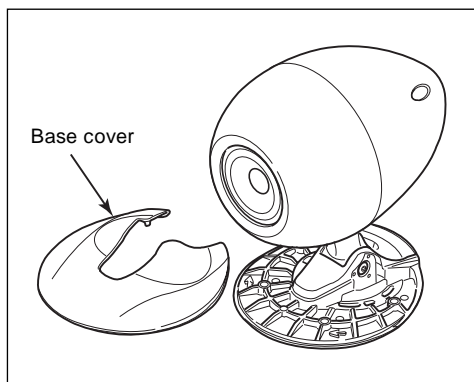

Take off the base cover.

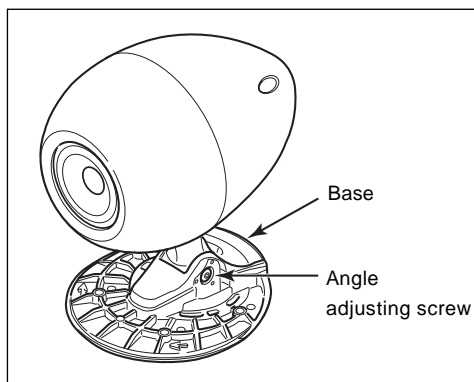

Loosen the angle adjusting screw with the hexagonal wrench provided as an accessory.

ADVICE

- To adjust the angle, lay the speaker on its side and move the base.

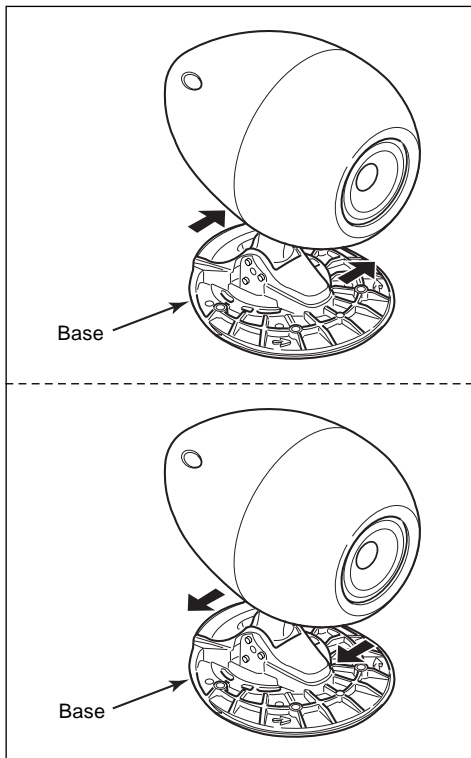

Slide the speaker a little in the direction indicated by the arrow in the figure to loosen the grip of the catch on the base.

Adjust the speaker angle to the required position then slide the speaker back to the left, check that the catch has engaged properly, and tighten the angle adjusting screw.

ADVICE

- To adjust the angle, lay the speaker on its side and move the base.

[2] Angle adjustment diagram

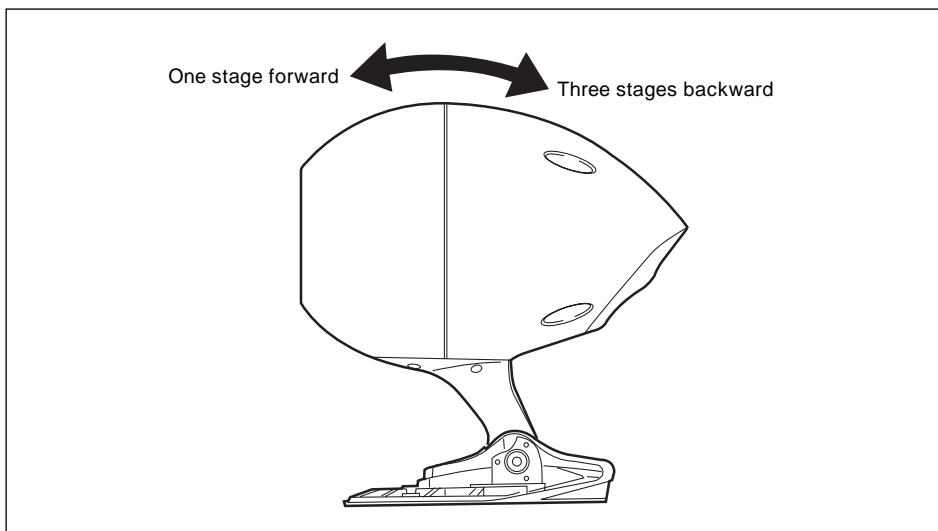

Fitting the Protective Mesh

[1] Installation of protective cover.

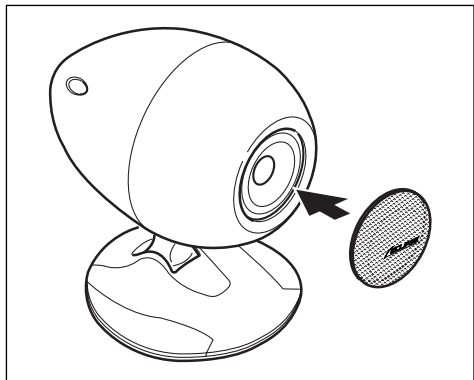

As shown in the diagram, install the protective cover.



ADVICE

The protective cover may be attached when the speaker is not in use or at the user's discretion.

Care / Specifications

Maintenance

Before maintaining the unit, ensure that the power is off and the power cord removed.

Remove any dirt from the unit by lightly wiping with a soft cloth.

If it is particularly dirty, use a slightly damp cloth to wipe it down, then use a dry cloth.

Do not use gasoline or thinners, etc. on this unit as it may damage the cabinet.

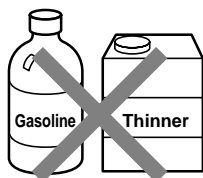

Problems during Operation of the Unit

During operation, the unit may stop working properly if it suffers from significant external disruption (impact shock, static electricity, voltage fluctuation caused by lightning, etc.) or is operated incorrectly.

In this situation, turn the amplifier power to switch to the "Off" position. Turn it back on again and check if normal operation has resumed.

(If a problem persists, please contact our Service Centre)

Notice for WEEE directive

In accordance with the WEEE directive, whenever this product is sold in member states of the EU after August 13, 2005 it must mandatorily bear the WEEE mark.

When disposing of this product in an EU member state, do so in accordance with the laws of that state, for example by returning it to the distributor.

WEEE : Waste Electrical and Electronic Equipment.

Specifications

Specifications and appearance are subject to change without prior notification.

TD508

Speaker diameter:	8cm
System:	Bass reflecting box
Allowable input:	Rating 12 W / Max. 24 W
Impedance:	8Ω
Dimensions:	W160 x D228 x H240 (mm)
Weight:	Approx. 3 kg

TD510

Speaker diameter:	10cm
System:	Bass reflecting box
Allowable input:	Rating 20 W / Max. 40 W
Impedance:	6Ω
Dimensions:	W286 x D363 x H373 (mm)
Weight:	Approx. 8.5 kg

Warranty and After-Service

Warranty Certificate (included)

After reading the contents of the Warranty Certificate, put it away in a safe place.

Warranty period

The warranty period is one year from purchase date. Some costs may be incurred even within the warranty period, so please read your Warranty Certificate carefully.

Life-span of Serviceable Parts

The life-span of the serviceable parts in this product is a period of 8 years from the date of manufacture. This is the period stipulated by the Ministry of International Trade and Industry. 'Serviceable parts' are defined as those parts which are necessary to ensure the functionality of the product.

Repairs and Enquiries

See "Customer Enquiries" Section on the included sheet.

When Requesting a Repair

Within warranty period

Present your Warranty Certificate
Repairs will be carried out in accordance with the conditions on the Warranty Certificate

Outside the warranty period

When a repair is possible, it will be carried out upon your instruction and at your expense.

 Regular Checks	After many years of use, check your audio equipment;	
	Are any of these conditions present?	An excessively hot power cord or plug A burning smell Deep cuts or abnormalities of the power cord Any other damage or abnormalities



Stop using the unit

To prevent damage and accidents, turn off the power switch, remove the power cord and request a service inspection.
For inspection and repair costs, please check with our Service Centre.

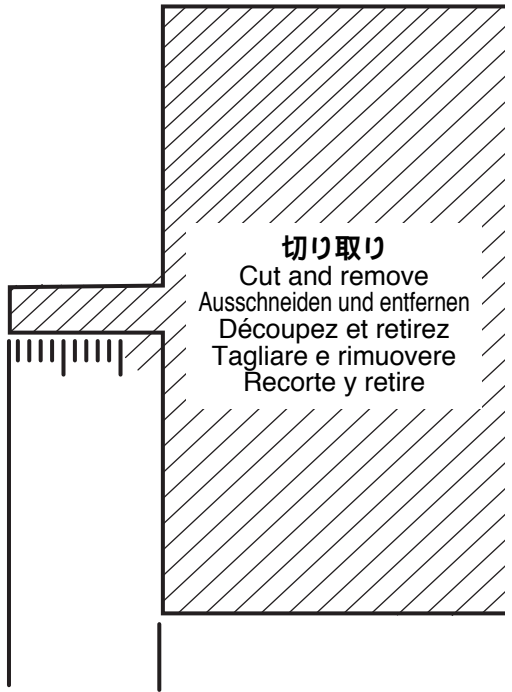

角度調整ねじ先端	ネック部	底面	角度 0°
Tip of the angle adjustment screw	Neck of the screw	Base	Angle 0 degrees
Spitze der Winkeleinstellschraube	Schraubenhals	Unterteil	Winkel 0 Grad
Pointe de la vis de réglage d'angle	Col de la vis	Base	Angle 0 degré
Punta della vite di regolazione dell'angolazione	Collo della vite	Base	Angolo 0 gradi
Punta del tornillo de ajuste del ángulo	Cuello del tornillo	Base	Angulo 0 grados

MEMO

FUJITSU TEN

090001-1478A700
0510MT(F)